

Investigation of the process of diamond formation from SiC under high pressure and high temperature

LI GOU, SHIMING HONG, QINGQUAN GOU

Institute of Applied Physics, Chengdu University of Science and Technology, Chengdu, People's Republic of China

SiC powder or graphite in contact with cobalt, nickel or a $\text{Ni}_{70}\text{Mn}_{25}\text{Co}_5$ alloy was treated at high pressure and high temperature in stable region of diamond. It was found that $\text{Ni}_{70}\text{Mn}_{25}\text{Co}_5$ alloy is more effective in the process of diamond formation from SiC than the others, but the difference was not apparent when graphite was used instead of SiC. Using the $\text{Ni}_{70}\text{Mn}_{25}\text{Co}_5$ alloy, diamond formed rapidly with the decomposition of SiC at a pressure of 5.4–6.0 GPa and temperature 1350–1570 °C, and the growth tended to stagnate after 6 min, when SiC was completely exhausted. X-ray diffraction showed that the relative intensity of the diffraction lines of diamond and graphite was nearly constant in the samples synthesized under the same conditions for 2, 4 and 6 min. The results suggest that diamond and graphite may be formed directly and respectively from separated carbon atoms in a short time.

1. Introduction

General Electric researchers have reported that graphite could transform to diamond in the presence of some metallic solvent-catalysts under high pressure and high temperature in the thermodynamically stable region of diamond [1, 2]. Since then, various carbonaceous materials, as well as some organic compounds, have been used to supply the carbon for diamond synthesis in either direct transformation or solvent-catalyst processes [3, 4]. Another kind of method has been patented to produce diamond via the decomposition of carbon-containing inorganic compounds such as carbides and carbonates [5–7]. Although it is interesting to consider the mechanism of diamond formation in a non-conventional process, details of the method have not been published in scientific journals.

In recent years, it has been reported that diamond could be synthesized from a system of SiC and a metal [8, 9]. The reaction process has been described as follows. SiC decomposed when the system is exposed to high pressure and high temperature. When affected by the metallic solvent-catalyst, carbon was partially separated as diamond and partially as graphite under the conditions in the stable region of diamond, while silicon could dissolve into and remain in the metal.

However, the experimental results are not yet sufficient to explain the mechanism of the reaction. It is still necessary to investigate details of the non-conventional process, and the possibility of any special properties of the diamond.

In this context, SiC and graphite were used as the carbon source and nickel, cobalt, and a $\text{Ni}_{70}\text{Mn}_{25}\text{Co}_5$

alloy as solvent-catalyst for synthesis of diamond under the various conditions, and also the systems of SiC and metal were held for different times under the same conditions of high pressure and high temperature. The experimental results were compared and some new features of the process were discovered.

2. Experimental procedures

As starting materials, 3C-type SiC powder (average grain size 100 μm , purity 99.95%) was placed alternately with several discs of cobalt, nickel or $\text{Ni}_{70}\text{Mn}_{25}\text{Co}_5$ alloy. The SiC and metal discs were put into a reaction container made of $\text{NaCl} + 20 \text{ wt } \% \text{ ZrO}_2$. Fig. 1 shows the sample configuration.

The high-pressure experiments were carried out in a cubic anvil apparatus, and each anvil top end was 23.5 mm long. Pressures were calibrated at 600–760 °C by the melting point of lead [10], while the temperature was estimated by extension of the relation between the input heating power and the e.m.f. of a (NiCr–NiSi) thermocouple; the pressure effect on the thermocouple e.m.f. was ignored.

The sample was first subjected to a high pressure and heated to the desired temperature, and held for the desired time. It was then cooled to room temperature and finally decompressed. The starting materials and experimental conditions are listed in Table I.

The sample obtained was first observed with an optical microscope, and the secondary electron image (SEI) of a scanning electron microscope. It was then treated with a hot mixture of HCl and HNO_3 to remove the metal. X-ray diffraction analysis was

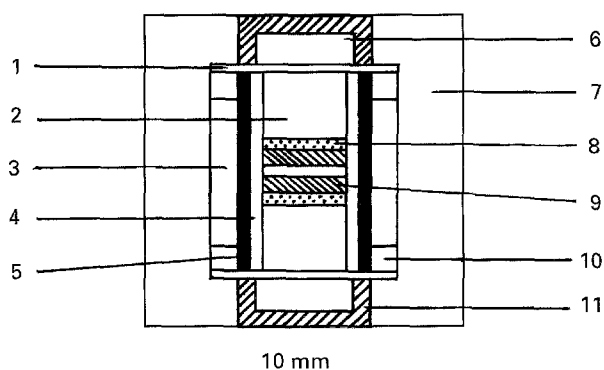

Figure 1 Sample assembly: 1, Mo plate; 2, 3, 4, NaCl + 20 wt % ZrO₂; 5, graphite heater; 6, 7, 10, pyrophyllite; 8, SiC or graphite; 9, metal plate; 11, steel ring.

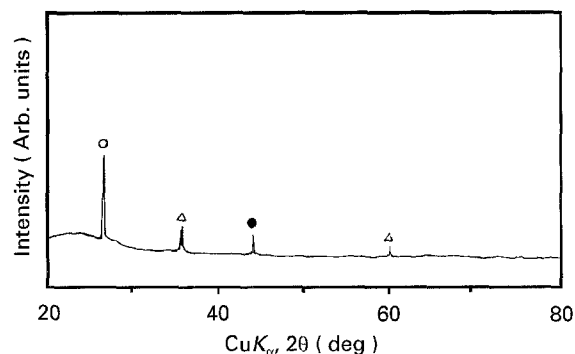

Figure 2 X-ray diffraction pattern of the sample C1. (Δ) SiC, (○) graphite, (●) diamond.

carried out before and after acid treatment. Some samples were also treated with a hot mixture of H₂SO₄ and HNO₃ (4:1) to remove graphite and to recover diamond. The starting materials and the diamonds obtained were weighted in a balance, and the grain-size distributions of the diamond crystals were measured by a system of laser particle analysis (Malvern Instruments).

3. Results and discussion

3.1. Difference of the effect of solvent-catalyst on the two kinds of carbon source materials

As shown in Table I, various metals were used as solvent-catalyst in contact with the SiC or graphite, and the two kinds of system containing the different carbon source materials were treated under similar conditions of pressure and temperature.

X-ray diffraction on the samples A1, A2, A3, B1 and B2, where nickel or cobalt were used, showed that the SiC peak was reduced in A1, A2, B1 and B2 and

disappeared in A3, while a sharp graphite line appeared, but no diamond line was seen in the diffraction patterns after acid treatment of the samples. Although diamond lines could be found in the patterns of samples B3, where cobalt was used and the holding time was longer, the diamond obtained was only very small.

In contrast, diamond lines appeared clearly in the X-ray diffraction patterns of samples C1–D4, and many diamond crystals, whose size ranged from a few to a hundred micrometres, were observed by optical microscopy in the samples, where Ni₇₀Mn₂₅Co₅ alloy was used. Fig. 2 shows the X-ray diffraction of C1 synthesized for a very short time. Although SiC could be detected, diamond and graphite lines appeared clearly.

Thus, it was confirmed that Ni₇₀Mn₂₅Co₅ alloy is more effective in the process of diamond formation from SiC, than cobalt or nickel.

On the other hand, diamond was easily synthesized in both samples E1 and E2, when cobalt and Ni₇₀Mn₂₅Co₅ alloy were used as solvent-catalyst, respectively, and graphite as the carbon source; the

TABLE I Starting materials and experimental conditions

No.	Starting material	Weight ratio	Pressure (GPa)	Temperature (°C)	Holding time (min)
A1	SiC + Ni	1:8	5.8	1510	5
A2	SiC + Ni	1:8	6.3	1460	5
A3	SiC + Ni	1:8	5.7	1460	14
B1	SiC + Co	1:8	5.7	1460	5
B2	SiC + Co	1:8	5.9	1570	5
B3	SiC + Co	1:8	6.0	1570	20
C1	SiC + Ni ₇₀ Mn ₂₅ Co ₅	1:6	6.0	1460	0.5
C2	SiC + Ni ₇₀ Mn ₂₅ Co ₅	1:6	6.0	1460	1
C3	SiC + Ni ₇₀ Mn ₂₅ Co ₅	1:6	6.0	1460	2
C4	SiC + Ni ₇₀ Mn ₂₅ Co ₅	1:6	6.0	1460	4
C5	SiC + Ni ₇₀ Mn ₂₅ Co ₅	1:6	6.0	1460	6
C6	SiC + Ni ₇₀ Mn ₂₅ Co ₅	1:6	6.0	1460	10
C7	SiC + Ni ₇₀ Mn ₂₅ Co ₅	1:6	6.0	1460	20
D1	SiC + Ni ₇₀ Mn ₂₅ Co ₅	1:8	5.4	1350	2
D2	SiC + Ni ₇₀ Mn ₂₅ Co ₅	1:8	5.4	1350	4
D3	SiC + Ni ₇₀ Mn ₂₅ Co ₅	1:8	5.4	1350	6
D4	SiC + Ni ₇₀ Mn ₂₅ Co ₅	1:8	5.9	1570	5
E1	Graphite + Co	1:4	5.9	1570	5
E2	Graphite + Ni ₇₀ Mn ₂₅ Co ₅	1:4	5.9	1570	5

synthesis conditions were the same as that for B2 and D4.

Diamond obtained from samples E1 and E2 was almost equal in weight: 62 and 61 mg, respectively (starting graphite 110 mg).

The results show that effect of solvent-catalyst on the behaviour of SiC is different from that on the graphite one. This experimental fact could suggest that the mechanism of diamond formation from SiC may be different from that of the conversion of graphite into diamond, in the presence of the metallic solvent-catalyst.

Another reason was also considered: when SiC decomposed and Si dissolved into the metal, the effect of silicon-rich solvent-catalyst on the carbon atoms differs from that of the metals containing no silicon.

3.2. Variation of productivity and grain size of diamond with reaction time

In order to investigate the process of diamond formation, SiC and $\text{Ni}_{70}\text{Mn}_{20}\text{Co}_5$ in the weight ratio 1:6 were treated under the same conditions for 2, 4, 6, 10 and 20 min in samples C3–C7.

Fig. 3 shows the relation between weight of diamond recovered and the holding time at high pressure and high temperature; Fig. 4 shows that between average grain size of the diamond crystals and time. As shown, productivity and average grain size of the diamond both increased remarkably with reaction time before 6 min, but they became almost constant from 6–20 min, suggesting that the rate of diamond formation was rapid before 6 min and then became very slow. The reason may be that diamond formed quickly owing to decomposition of SiC, and then growth tended to stagnate after 6 min when the SiC was completely exhausted. Although the partially produced graphite could then transform continually to diamond, the conversion of the carbon may become difficult when the concentration of silicon in the solution became high.

3.3. Composition of the samples treated for a short time

In the light of the above phenomena and discussions, the investigation was focused on the samples treated for a short time. Fig. 5 shows the X-ray diffraction patterns of samples D1, D2 and D3 after acid treatment, where SiC and $\text{Ni}_{70}\text{Mn}_{25}\text{Co}_5$ alloy were used in the weight ratio 1:8 and were held under the same conditions for 2, 4 and 6 min. It was clear that SiC lines almost disappeared, while diamond and graphite appeared in the samples.

However, it was noticed that the relative intensity of the diffraction lines of diamond and graphite was nearly constant in the samples. It may be suggested that the conversion process of graphite into diamond or vice versa does not occur before 6 min. In other words, diamond and graphite formed directly and respectively from separated carbon before the end of SiC decomposition.

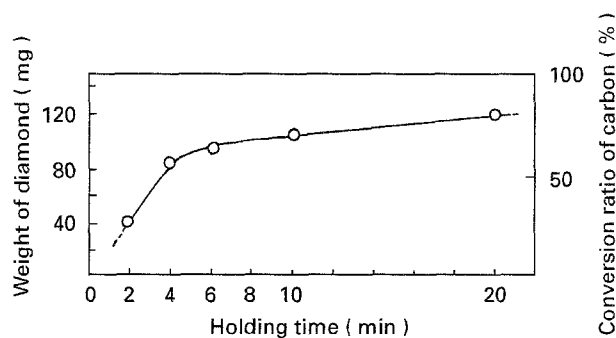

Figure 3 Relation between weight of diamond and the holding time for samples C3, C4, C5, C6 and C7.

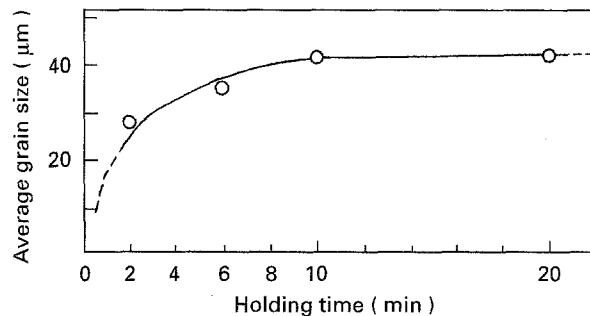

Figure 4 Relation between average grain size of diamond and holding time for samples C3, C5, C6 and C7.

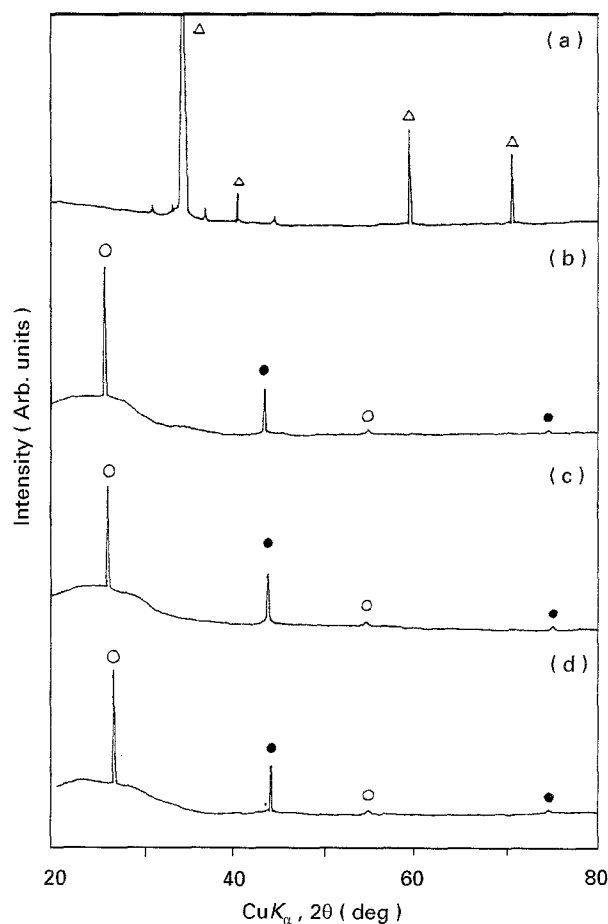

Figure 5 X-ray diffraction patterns: (a) SiC in starting materials; (b–d) samples D1, D2 and D3 after acid treatment. (Δ) SiC, (\circ) graphite, (\bullet) diamond.

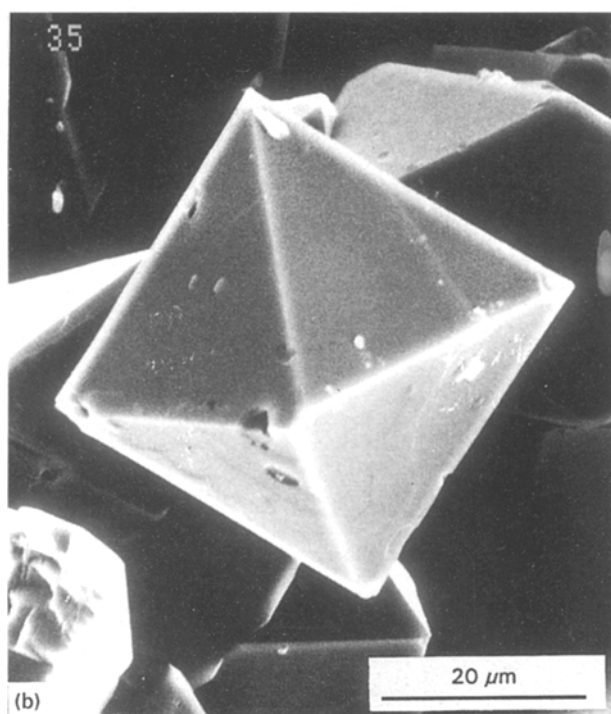
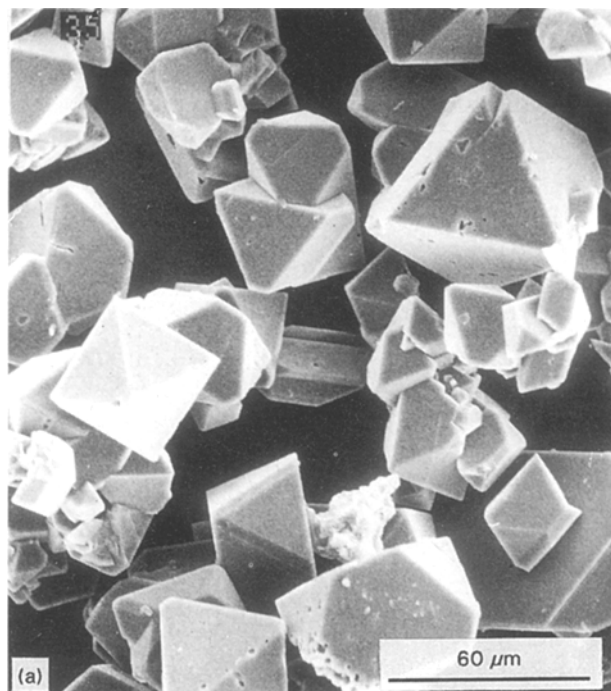

Figure 6(a,b) Secondary electron images of the diamond crystal in the sample D4.

3.4. Morphology of the diamond crystals

Grain size and the shape of diamond crystals synthesized from SiC with $\text{Ni}_{70}\text{Mn}_{25}\text{Co}_5$ alloy depend on the conditions of pressure and temperature. The tendency was similar to that of diamond synthesized by graphite.

The diamond crystals have a more perfect shape and a more homogeneous grain size although the

average grain size is smaller. As a feature, many developed $\{111\}$ facets could be observed in the diamond. Fig. 6 shows examples of the crystals obtained. The crystal colour is yellowish.

4. Conclusion

Diamond could be synthesized from a system of SiC and $\text{Ni}_{70}\text{Mn}_{25}\text{Co}_5$ alloy under high pressure and high temperature. $\text{Ni}_{70}\text{Mn}_{25}\text{Co}_5$ alloy was effective in the diamond formation from SiC, rather than cobalt or nickel. The difference in the effects of solvent-catalyst was not apparent when graphite was used as the carbon source material under similar conditions.

Using the $\text{Ni}_{70}\text{Mn}_{25}\text{Co}_5$ alloy, diamond formed rapidly with the decomposition of SiC at a pressure of 5.4–6.0 GPa and temperature 1350–1570 °C, and the growth tended to stagnate after 6 min, when SiC was exhausted completely.

X-ray diffraction showed that the relative intensity of diamond and graphite lines was nearly constant in the samples treated under the same conditions for 2, 4 and 6 min. It may be suggested that diamond and graphite could be formed directly and respectively from separated carbon atoms in a short time.

Acknowledgements

The project was supported by the National Natural Science foundation of China.

References

1. F. P. BUNDY, H. T. HALL, H. M. STRONG and R. H. WENTORF JR, *Nature* **176** (1955) 51.
2. H. P. BOVENKERK, F. P. BUNDY, H. T. HALL, H. M. STRONG and R. H. WENTORF JR, *ibid.* **184** (1959) 1094.
3. R. H. WENTORF JR, *J. Phys. Chem.* **69** (1965) 3063.
4. F. P. BUNDY, H. M. STRONG and R. H. WENTORF JR, in "Chemistry and physics of carbon", edited by P. L. Walker Jr and P. A. Thrower, Vol. 10 (Marcel Dekker, New York, 1973) pp. 213–63.
5. E. WOLF, H. OPPERMAN, H. HENNIG, U. GERLACH, G. GLOSSE and G. RISSE, Ger. (East) Pat. DD259 147 (1988).
6. U. GERLACH, H. HENNIG, H. OPPERMAN, G. RISSE and E. WOLF, Ger. (East) Pat. DD257 375 (1988).
7. E. WOERMANN, Ger. pat. 2721 644 (1978).
8. S. M. HONG, and M. WAKATSUKI, *J. Mater. Sci. Lett.* **12** (1993) 283.
9. S. M. HONG, W. LI, X. P. JIA and M. WAKATSUKI, *Diamond Rel. Mater.* **2** (1993) 508.
10. S. M. HONG, X. J. LUO, S. X. CHENG and Y. G. WANG, *Chin. J. High Press. Phys.* **3** (1989) 159.

Received 9 August 1994

and accepted 21 February 1995